

megamount 801



For Sports car wheels with rims of large diameter and width

That is self-evident for us:

- Pneumatic function of mounting head and mounting shaft
- Pneumatic mounting tool
- 2 clamping cylinders
- Rim clamping inside 14-26 inches, outside 12-24 inches
- Maximum rim width 16 inches
- Maximum tyre diameter 1200 mm
- Filter with pressure regulator and manometer for 10 bar working pressure
- Inflating pressure limiting device 3,5 bar (CE)

With Option helping arms.

The competition might not have this:

- Bead breaker 3,1 tons. Also for the stiffest tyres
The parallelogram form of the shovel prevents an inadvertent contact and damage of the rim
- Accessories for professional and careful mounting of extreme low profiled tyres

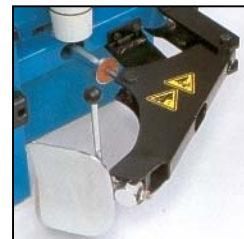

For all problems the right solution:



- MOUNTING ARM
Tiltable back and forth pneumatically
- MOUNTING SHAFT
Extreme rigid construction. Manufactured from precision cast-steel. Pneumatic height adjustment
- MOUNTING HEAD
Optimised profile for high efficiency when working with different dimensions of tyres and rims. AUTOMATIC ANGLE MECHANISM for correct setting in vertical, horizontal and diagonal position.



- BEAD BRAKER
Zinc plated high power cylinder 3,1 tons. Special contoured flexible blade with parallelogram form which prevents inadvertent contact and damage of the rim.
- CLAMPING SYSTEM
Self-centring four jaw chuck with two rotation speeds (7 und 14 rpm). Markings for the pre-selection of the clamping jaws.

This comes with the machine:

- Lubricator
- Mounting paste with brush
- Tyre lever
- Filter with 10 bar operating pressure limiting device and manometer
- CE 3,5 bar inflating pressure limiting device
- Michelin inflating pistol

Options intelligent and universal

- Filling systems through clamping jaws (Tubeless)
- Protecting caps for mounting alloy rims
Allows also tubeless filling of alloy rims
- Bead braking instrument for extreme low profiled tyres
- Pneumatic wheel lift
- Quick locking system for different mounting heads
- Helping arm for the mounting of extreme low profiled tyres

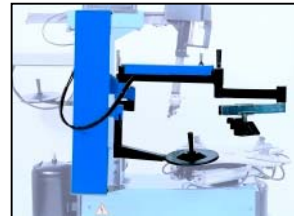

Technical Data	
Compressed air supply	8 bis 12 bar
Three-phase motor	230 - 400 V / 50 Hz / 550 W
Motor single phase (Option)	220 V / 50 Hz 750 W
Self-centring lock external	12 - 24 inches
Self-centring lock internal	14 - 26 inches
Max wheel diameter	1200 mm
Max rim width	16 inches
Bead braker pressure	3100 kg
Dimensions, packed (WxDxH)	1113 x 1139 x 1113 mm
Gross weight, packed	330 kg

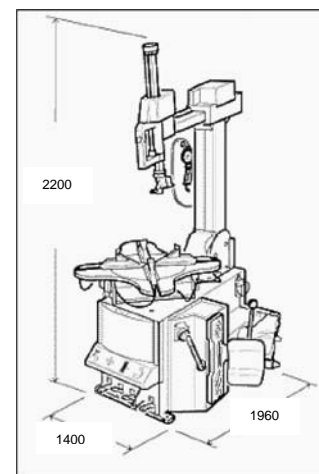

HOFMANN MEGAPLAN GMBH
Hauptstraße 59
A-5302 Henndorf • Austria
Tel: +43-6214-646612 Fax - 646622
company@hofmann-megaplan.com
www.hofmann-megaplan.com